

Homeowner electrical wiring guide

(Including the 2015 Canadian Electrical Code amendments)

This document is only a guide. Other methods of installation may be acceptable, but must meet the minimum requirements of the current Canadian Electrical Code. As a homeowner, you need a basic knowledge of electrical wiring.

Required inspections

Homeowner permits require a minimum of two inspections, rough and final. Please call the Town of High River Safety Codes Department at 403-603-3468 or e-mail inspection requests at permits@highriver.ca for all required inspection phases of construction.

- Call at least two working days in advance.
- Access must be arranged by homeowner and someone 18 years or older must be present.
- Appointments are not possible; inspections are available Monday & Wednesday.
- Electrical inspections are separate from plumbing, gas and building permit inspections.

Rough inspections (prior to any concealing)	Final inspection (electrical complete)
<ul style="list-style-type: none">• Have all wiring and interior of boxes readily visible.• Do not secure devices (plugs, switches) to boxes. Devices do not need to be installed for the rough inspection.• Remove vapour barriers and insulation where it's covering any wiring. The exception is for wiring fished into walls.• Terminate all wiring into boxes and fixtures and remove outer jackets.• All wiring must be supported.• Cables may be terminated into the panel board, but should not be on breakers.• Rough and underground inspections should be combined.• Never energize exposed wiring.	<ul style="list-style-type: none">• Do not have any exposed live wiring.• All outlets, light fixtures and cover plates must be in place.• All branch circuits must be energized for inspection.• The panel board breaker directory must be completed.• A permit services report will be mailed to the owner after an acceptable inspection. <p><i>Note: Although preferred, it is not necessary to have the wallboard installed for a final inspection.</i></p>

Deficiencies and failed inspections

The Electrical Safety Codes Officer will advise if noted corrections are “not acceptable” and require a re-inspection, or if they are “acceptable or acceptable with conditions” and the installation may proceed.

Panel boards (service and sub-panels)

DO	DON'T
<ul style="list-style-type: none"> • Have 1m clearance with secure footing in front. • Have adequate lighting. • Have minimum headroom of 2m. • Identify all branch circuits to what they serve. 	<ul style="list-style-type: none"> • Put panels in closets, bathrooms or stairways. • Have any breaker more than 1.7m above the floor. • Relocate or change the panel board without an electrical contractor and an electrical contractor permit.

Non-metallic sheathed cable NMD90 (Lumex) and armoured cable branch circuit wiring

- Support cables with approved straps or staples within 300mm of an outlet box and at intervals of 1.5m thereafter.
- **An approved mechanical protection plate is required where cables are:**
 - **within 32mm of the stud/joist face surface, or**
 - **subject to damage from nails or screws where located behind baseboards or cupboards**

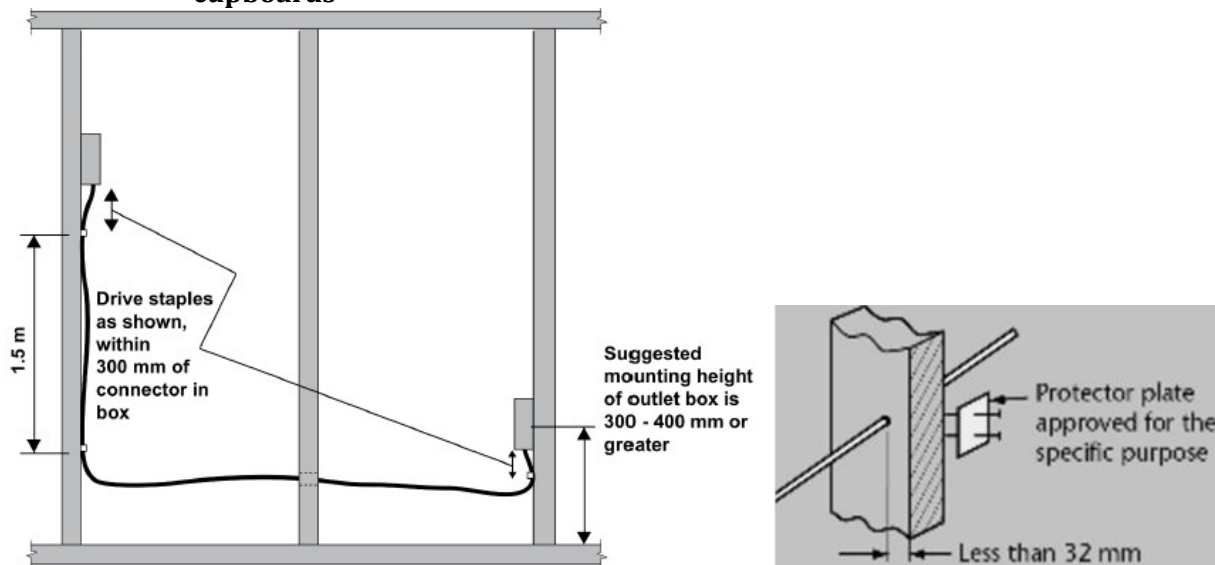

- Exposed cables within 1.5m of the floor require mechanical protection.
- Cables require a minimum separation of 25mm from heating ducts.

- Communication (TV, phone, speaker) cables require a minimum separation of 50mm from power and lighting cables.
- Do not fish lumex cable into walls with metal studs.
- Lumex cable run through metal studs will require approved bushings or grommets, to protect the wire from sharp edges.
- A minimum 150mm of conductor length is required when inserting into boxes and fixtures.
- 240V loads such as electric heating, air conditioners, etc. should use lumex cables with a red outer jacket.

Fittings, devices and junction boxes

The maximum number of conductors allowed in outlet boxes:

Box type	Dimensions H X W X D	Box volume Millilitres	Number of #14 AWG wires. (Black, white wires)
Octagon (light)	4 X 1-1/2 deep	245ml	9 wires with 3 wire nuts
	3 X 2 X 2-1/8 deep	344ml	13 wires with 3 wire nuts
Plug or switch (Device)	3 X 2 X 2	163ml	3 wires with 3 wire nuts and 1 device.**
	3 X 2 X 2-1/2 deep	204ml	5 wires with 3 wire nuts and 1 device. **
	3 X 2 X 3 deep	245ml	7 wires with 3 wire nuts and 1 device. **
	2 gang 2-1/2 deep	409ml	11 wires with 3 wire nuts and 2 devices.**
	2 gang 3" deep	491ml	15 wires with 3 wire nuts and 2 devices.**
	3 gang 2-1/2 deep	614 ml	18 wires with 3 wire nuts and 3 devices.**
Square (Junction).	4 X 1-1/2	344ml	14 wires. Deduct for wire nuts.
	4 X 2-1/8	491ml	20 wires. Deduct for wire nuts.

Where a box contains a dimmer switch or a GFCI outlet, deduct an additional wire for each.

- Fasten all outlet boxes securely in place.

- Install all outlet boxes flush to the finished wall.
- Ceiling fan outlet boxes must be approved.
- Unused openings in boxes and panels must be closed by approved covers.
- Cable boxes mounted on metal studs must be approved.
- **When used with lighting, vapour barriers must be approved for 90°C.**
- **Hydro-massage** bathtubs require removable access panels for maintenance.
- Secure grouped outlet boxes and outlet boxes that are greater than 4” on two sides:

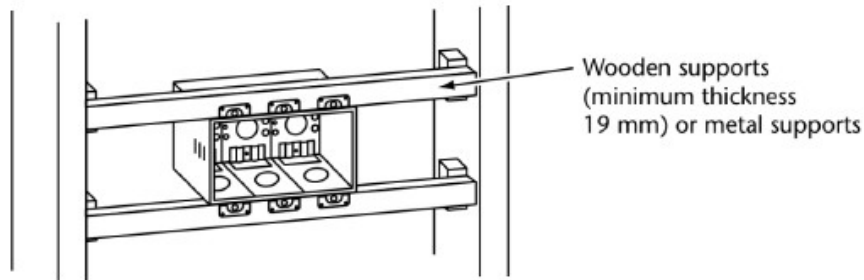

Lighting and fixtures

- Do not install fixtures with a bare light bulb in closets.
- Protect light fixtures that are less than 2.1m high with a guard or by location.
- Pot lights not marked “TYPE IC” must be at least 13mm from combustible materials or 76mm from insulation or in accordance with the manufacturer’s instructions.
- You may be asked to remove a retro-fit pot light installed after the rough inspection, to verify the installation.
- Three-way switching is required at the top and bottom of stairways with four or more stairs that lead to a finished area or to an outside entrance.
- The furnace disconnect switch must be accessible. Often when a basement is developed, the existing switch will need to be relocated. This location is for emergency purposes, so access to the furnace disconnect switch must be reachable without passing the front of the furnace.
- **Utility room lights must be controlled by a wall switch at the entrance.**
- Light switches must be more than 1m away horizontally from a bathtub or shower stall. If not possible, they must be at least 500mm away and protected by a Ground Fault Circuit Interrupter (GFCI).

Receptacles (outlets)

- Any outlet installed within 2m from the floor must be tamper resistant.
- **Outlets must be no more than 3.6m apart in every open room and no more than 1.8m from a door or closet. Any wall space of 900mm or more in width requires an outlet.**
- Outlets must be no more than 4.5m apart in a hallway.
- Outlets must be no more than 1.8m apart measured along the wall behind a counter top, and no more than 900m from a sink, stove or end point.
- No more than 12 outlets should be on a branch circuit.
- Each fixed kitchen island or peninsula larger than 600m x 300m requires at least one outlet (15A split or 20A T-slot).

- Each gas stove requires an outlet not more than 130mm from the floor and as near midpoint as possible.
- A 14-50R stove outlet with #8 AWG wire must not exceed 130mm to the centre from the floor and as near midpoint as possible, with the U ground slot at the side.

- Do not place outlets in a cupboard, cabinet or similar enclosure, except where the outlet is for a specific type of appliance that is suitable for installation within the enclosure (i.e. a microwave).
- Install one outlet protected by a Class A Ground Fault Circuit Interrupter (GFCI) within 1m of the bathroom or washroom wash basin. These outlets should be located between 500mm and 1m from a bathtub or shower.
- **Each laundry area requires an outlet, in addition to the washing machine.**
- Dryer outlets are type 14-30R with #10/3 AWG cables.
- An outlet is required to be installed within 1m of a garage door opener.
- Each car space in a garage requires one outlet.



Outdoor outlets require covers approved for wet locations and must be marked **extra duty**.

Receptacles in a kitchen

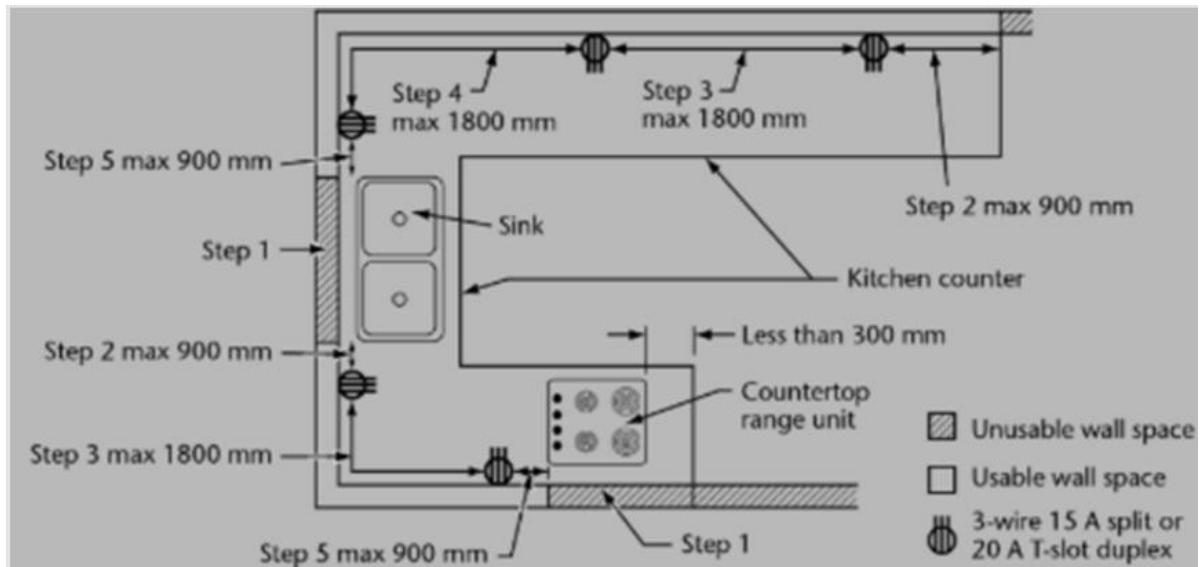

Receptacle layout

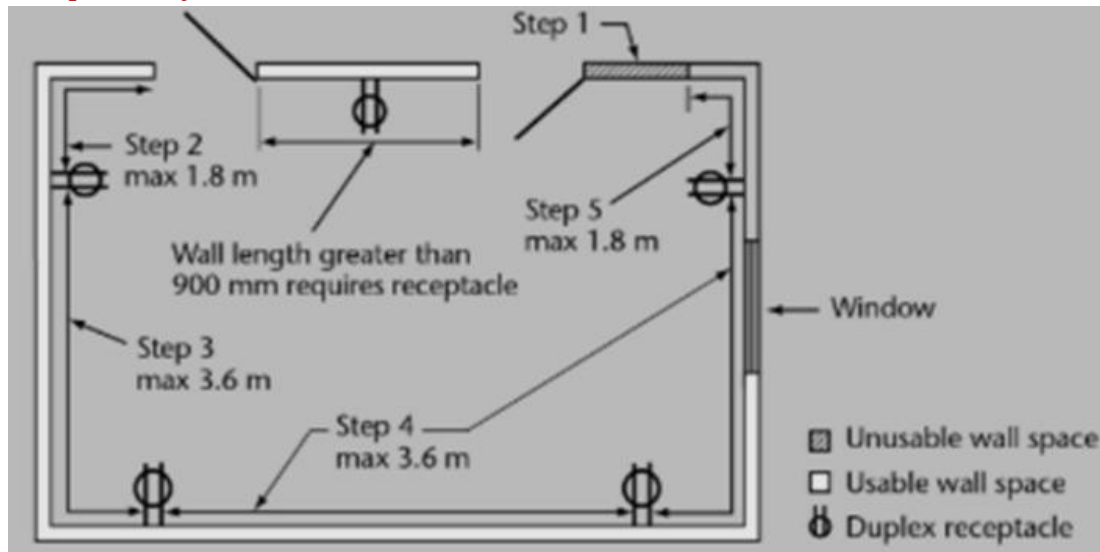

Branch Circuit wiring requirements

DO	DON'T
<ul style="list-style-type: none"> • Have separate branch circuit for refrigerators, dishwashers and microwaves. • Have electrical heat on a dedicated breaker. • Have outdoor outlets on a separate breaker • Install smoke and carbon monoxide alarms on a hard wired 120V breaker, with at least one light. These must not be on a circuit protected by Arc fault or ground fault circuit interrupters. Only a Building Safety Codes Officer can determine acceptable locations. • Have at least one outlet on its own breaker for utility rooms. • Have a separate breaker provided solely to supply power to each central vacuum system. 	<ul style="list-style-type: none"> • Have more than 12 outlets on a breaker. • Have more than two kitchen outlets on a 2 pole 15A breaker or single 20A breaker.

Ground fault protection

- 15A and 20A outlets installed within 1.5m of a sink, bathtub or shower must be GFCI protected.
- Exterior outlets within 2.5m of finished grade must be GFCI protected (automotive heater and charging outlets are exempt).
- Hydro-massage and hot tubs must be Class A ground fault protected.

- Ground fault circuit interrupters must be installed in a location that will facilitate testing. They cannot be closer than 3m to a hot tub and not closer than 1.5m to a hydro-massage bathtub.
- **Light switches (including fan and heat controls) located between 500mm and 1m horizontally from a bathtub or shower stall must be protected by a GFCI.**

Arc-fault protection

On Jan. 1, 2015, the Canadian Electrical Code requirements for arc-fault protection changed. Special wiring methods are required for most residential outlet branch circuits. **All branch circuits in a dwelling supplying 125V outlets rated 20A or less are to be protected by a combination-type arc-fault circuit interrupter (AFCI).**

Only the following 15A or 20A outlets are **excluded**:

- Kitchen counter, island and peninsula outlets
- Kitchen refrigerator outlet
- A cord connected sump pump on a separate breaker (the sump pump must only be plugged into a single receptacle)
- Ground fault protected outlets within 1m of a bathroom or washroom sink

Where combination AFCI breakers are not used, blank face protectors and outlets are permitted with some restrictions.

Each application has a preferred installation method based on level of protection and practicality.



The branch circuit wiring from the Panel board to the blank face device or first outlet must be armoured cable (AC90 BX) or approved electrical tubing. This is to add additional protection to the branch circuit wiring where breakers are not used.



Breakers must be marked “combination”; Branch/Feeder breakers are no longer acceptable.

Underground installations

Click before you dig: www.albertaonecall.com/homeowners

Direct buried conductors, cables or raceways must be installed to meet the minimum cover requirements. Distance measured is between finished grade and top of conduit or cable.

Wiring type	Non vehicle areas	Under vehicle traffic
Type NMWU direct buried**	600mm	900mm
Type NMWU in rigid PVC	450mm	600mm
Armoured cable (TECK90).	450mm	600mm

**Screened sand or backfill required.

Cables or conductors installed underground in a PVC conduit must be acceptable for use in wet locations (NMD90 is not acceptable).

- Protect cables exiting from underground from mechanical damage by location or by rigid PVC conduit.
- Gas lines (i.e., house to garage) are the homeowner’s responsibility. When electrical conductors are installed in the same trench, it is recommended that the two systems be separated by 300mm of well tamped soil or a 50mm treated plank.
- To prevent damage to the conductors or the electrical equipment, use a conduit expansion joint where underground PVC conduits or cables could be affected by settlement or frost.
- Do not place backfill containing large rock, paving materials, cinders, large or sharply angular substances or corrosive material where it may damage or corrode cables or conduits and prevent adequate compaction of the soil.

Use of approved electrical equipment

Electrical products and equipment must be approved by a Certification body, recognized by the Standards Council of Canada. Refer to the Alberta Electrical Safety STANDATA (LEG-ECR-2) found on the [Alberta Municipal Affairs website](#) for acceptable markings.

Quick reference for various installations

Installation type	Breaker size	Cable size	Size of conduit underground
Single circuit	15 Amp Combination Arc-fault.	14/2 NMWU	3/4" Rigid PVC
240volt 30A sub-panel	2 Pole 30A	10/3 NMWU	1" Rigid PVC
240V 40A sub-panel	2 Pole 40A	8/3 NMWU	1-1/4" Rigid PVC
240V 60A sub-panel	2 Pole 60A	6/3 NMWU	1-1/2" Rigid PVC
240V 50A	2 Pole 50A (Breaker Marked 75°C)	8/3 NMD90	
240V 60A	2 Pole 70A (Breaker Marked 75°C)	6/3 NMD 90	

Typical outlet box

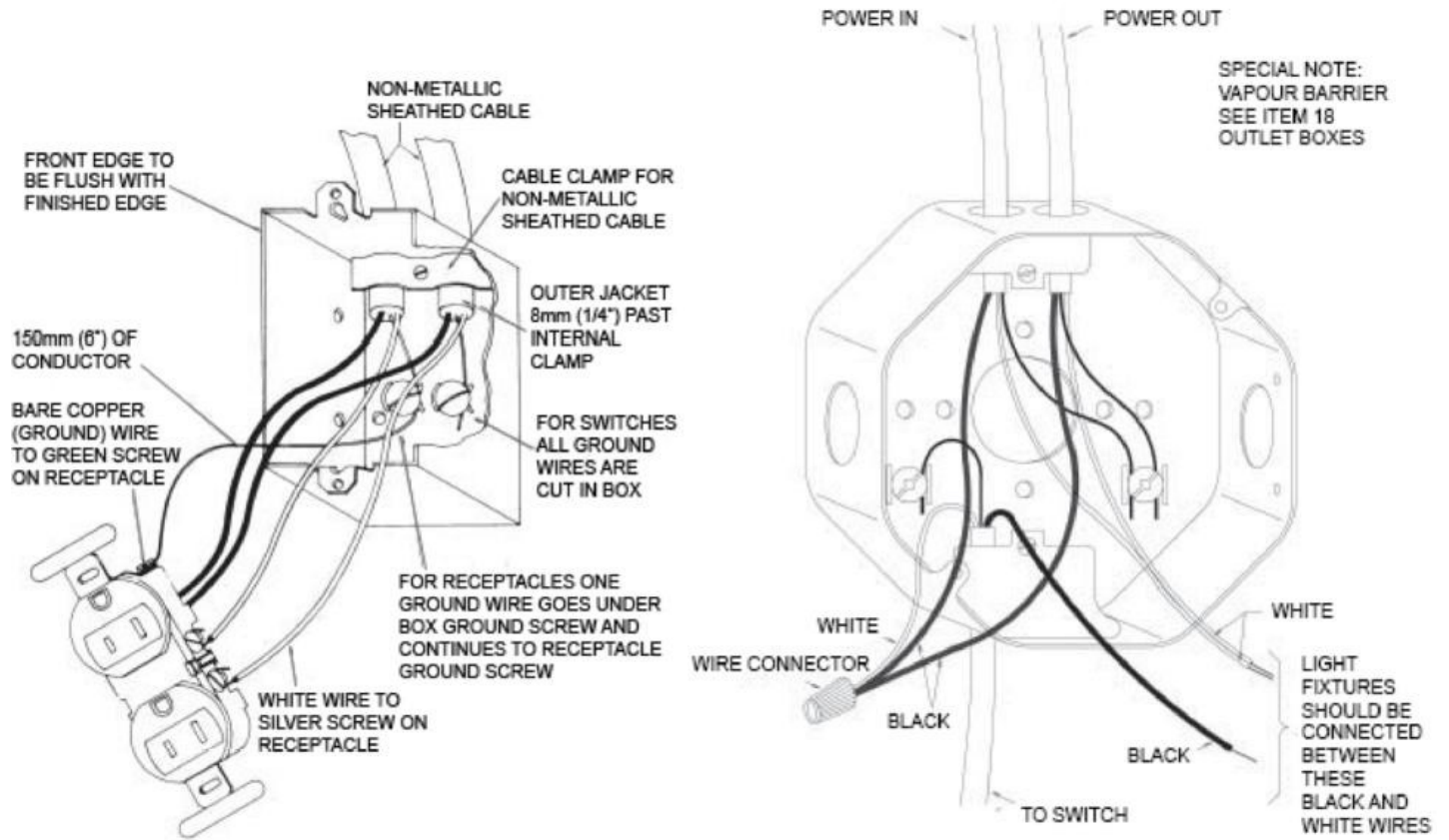

Three-way wiring configuration

